

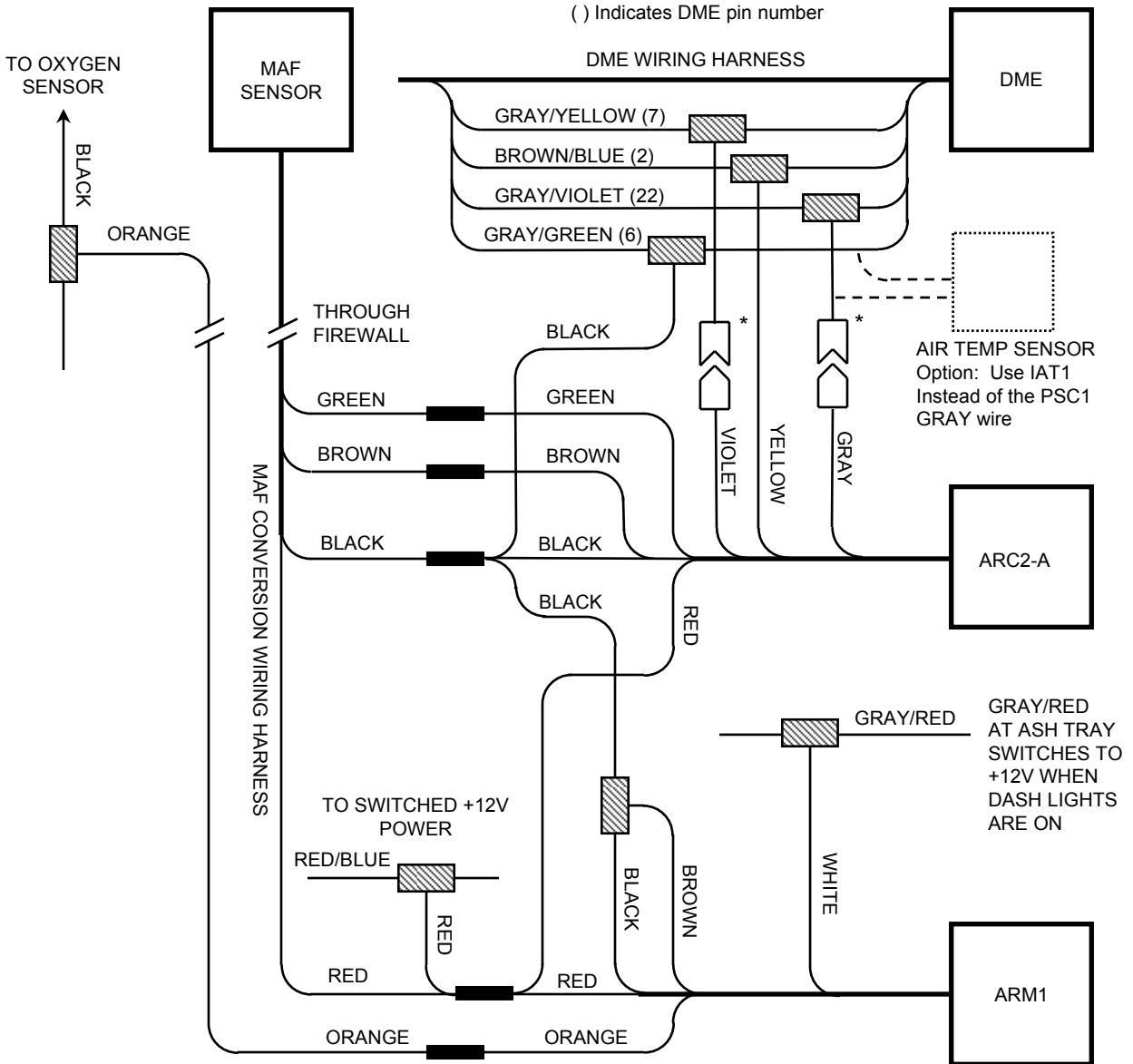



# Wiring For MAF Conversion on E30 M3 BMW using ARC2-A



-  BUTT SPLICE CONNECTOR
-  RING CRIMP CONNECTOR
-  INSTANT SPLICE CONNECTOR
-  IN-LINE CONNECTOR

\* NOTE: IN-LINE CONNECTORS MUST BE DISCONNECTED IF THE STOCK AIR FLOW METER IS RECONNECTED